

B.F. SERVICE

FRESA PER SPIANATURA
FACE MILLING CUTTER

NEW!!!

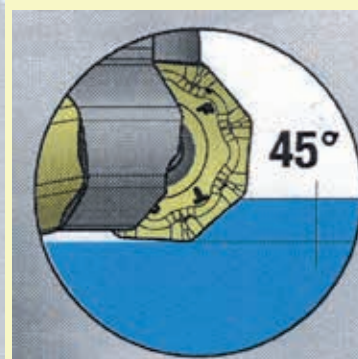
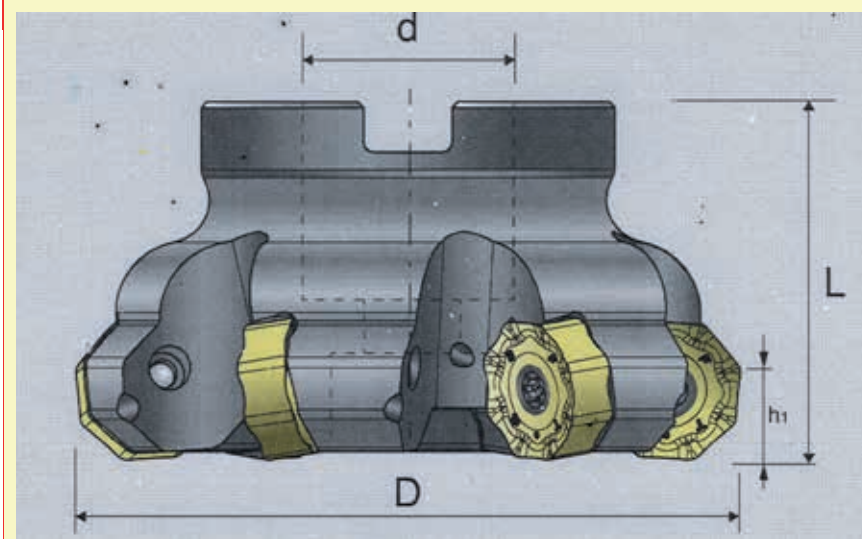

CODICE CODE	NUMBER OF INSERTS	D	L	h1	d
A-DSM-H08-050.R.04	4	50	40	5,0	22
A-DSM-H08-063.R.05	5	63	45	5,0	22
A-DSM-H08-080.R.06	6	80	50	5,0	27
A-DSM-H08-100.R.07	7	100	50	5,0	32
A-DSM-H08-125.R.08	8	125	60	5,0	40
A-DSM-H08-160.R.10	10	160	63	5,0	40

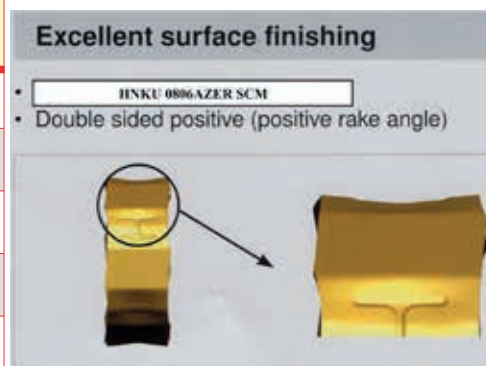

INSERTO INSERT	BFP123 BFC315N	BFC315N	BFC523
HNKU 0806AZER SCM	•	•	•

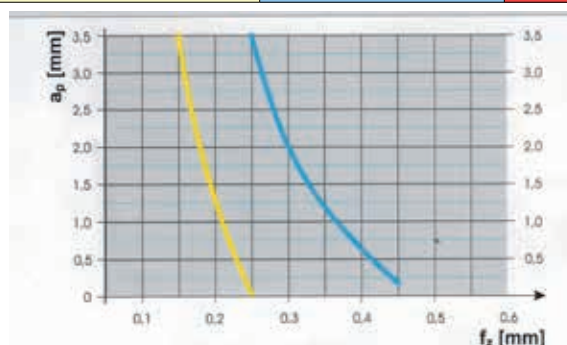

INS. HNKU0806AZER SCM/HCM

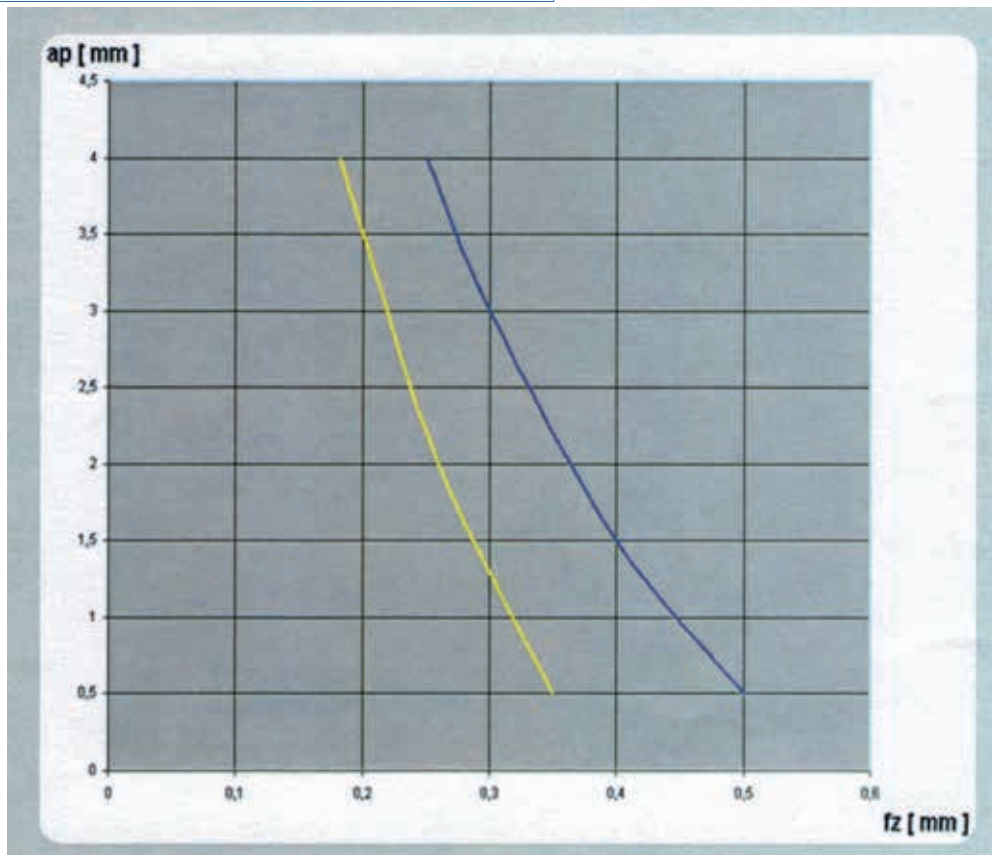

WHICH GEOMETRY TO USE ?



P
M
S

SCM

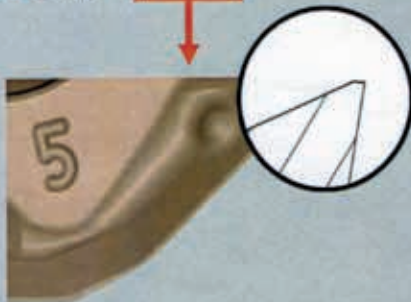

Sharp cutting edge for general stainless steel application and for finishing in steels



K

HCM

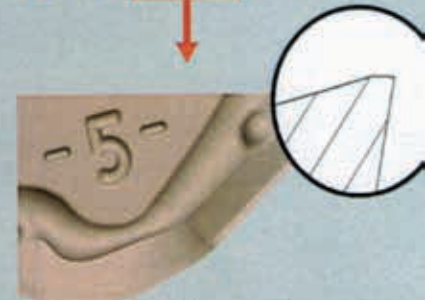

Strong cutting edge for general steel applications, and hard conditions milling